

QSE-CI-DMX Control Interface

Description

The QSE-CI-DMX operates either in a standalone QS system, a Quantum system, an Athena system, or a HomeWorks system. It performs different functions depending on the system in which it is operating.

QS Standalone System

The QSE-CI-DMX control interface allows zones on a GRAFIK Eye QS to control DMX512-controlled devices. Any zone on the GRAFIK Eye QS can be mapped to either a single DMX512 channel or to three separate DMX512 channels, for RGB/CMY color-control applications.

Quantum, Athena, or HomeWorks Systems

The DMX channels (maximum of 32) are mapped to Quantum, Athena, or HomeWorks zones, and can be programmed as 1-channel lighting, 1-channel integration, or 3-channel RGB/CMY. If the QSE-CI-DMX is part of a Quantum or HomeWorks system, GRAFIK Eye QS zones cannot be programmed to control DMX channels.

Features

- Map any zone on a GRAFIK Eye QS control unit (in QS Standalone systems) or any zone in a Quantum, Athena, or HomeWorks system to any single DMX512 channel
- Map any zone on a GRAFIK Eye QS control unit, any Quantum zone, Athena zone, or any HomeWorks zone simultaneously to three DMX512 channels for RGB/CMY color-control
- Integral RGB/CMY lookup table that maps GRAFIK Eye QS zone intensities, Quantum zone intensities, Athena zone intensities, or HomeWorks zone intensities to RGB/CMY values (colors)
- RGB/CMY table can be customized by using the Lutron QS Color Configuration Tool within the HomeWorks Designer, Quantum Q-Design, or Athena design software.



<p>Job Name:</p> <p>Job Number:</p>	<p>Model Numbers:</p>
--	-----------------------

Specifications

Regulatory Approvals

- RoHS Compliant
- CE Marked
- NOM
- cULus

Power Requirements

- Low-voltage SELV/PELV/NEC® Class 2
- Operating Voltage: 24–36 V $\overline{=}$ 65 mA

Environment

- 32 °F to 104 °F (0 °C to 40 °C).
- Relative humidity less than 90% non-condensing.
- Unit generates heat, maximum 8 BTU/hr.

System/Device Capabilities/Limits

- Each QSE-CI-DMX control interface counts as 1 QS device and 0 zones. For QS system link limits, refer to the Lutron Residential and Commercial System Rules Specification Submittal (P/N 369982) at www.lutron.com for more information.
- Each DMX channel = 1 switch leg. Refer to the Lutron Residential and Commercial System Rules Specification Submittal (P/N 369982) at www.lutron.com for more information.
- One QSE-CI-DMX per QS link in QS standalone. Up to 16 QSE-CI-DMX interfaces per QS link in HomeWorks, Athena, or Quantum systems.
- 32 DMX channels per QSE-CI-DMX control interface.
- Each QSE-CI-DMX control interface consumes 2 Power Draw Units (PDU) on the QS link. Refer to the QS Link Power Draw Units Specification Submittal (P/N 369405) at www.lutron.com for more information.

QS Link Wiring Limits

- Total length of link must not exceed 2000 ft (610 m).
- Do not allow SELV/PELV/NEC® Class 2 wires to contact line/mains wires.

DMX512 Link System Limits

- Consult your DMX equipment installer.

DMX512 Link Wiring Limits

- Each terminal can accept up to two 18 AWG (1.0 mm²) wires.
- Link must be 1000 ft (305 m) or less.
- DMX Link must begin and end with link terminators (available from Lutron; part number LT-1a).
- Three pins on the DMX connector for connecting the QSE-CI-DMX to DMX512-controlled equipment.

Limitations

- In a Quantum, Athena, or HomeWorks system, the 32 channels can be any of the 512 available addresses within the DMX universe. DMX mergers can be used if more than 32 DMX channels need to be controlled within a single DMX universe.
- Daylighting is not supported for DMX loads.
- Loadshedding is not supported for DMX loads.
- Nightlighting is not supported for DMX loads.
- DMX 1-channel lighting can be raised/lowered, but DMX 1-channel integration and DMX 3-channel lighting cannot.

Note: In a QS standalone system, raise/lower can be used to cycle through colors from a customizable RGB color table using the Lutron QS DMX Color Programming Tool.

Requirements

The QSE-CI-DMX requires the following:

- At least one GRAFIK Eye QS control unit connected to the QSE-CI-DMX through the QS communication link, *or*
A Quantum system
or
A HomeWorks system
or
An Athena system
- QS Link power supply capable of providing 2 PDUs. Refer to the QS Link Power Draw Units Specification Submittal (P/N 369405) at www.lutron.com for more information.
- DMX512 link terminators at both ends of the DMX512 link (available from Lutron, part number LT-1a)
- QS Communication Link Wire (SELV/PELV/NEC® Class 2). See the **Wire Sizes** table.

Job Name:	Model Numbers:
Job Number:	

Example Application

The QSE-CI-DMX can be programmed so that any or all zones on a GRAFIK Eye QS control unit can control either 3 channels (e.g., RGB) or 1 channel (i.e., intensity of a single light). Raising or lowering a zone will change the color (for a 3-channel zone) or the intensity (for a 1-channel zone).

If, for example, you have an RGB LED fixture and a single stage light, you can configure your settings as shown in the table below:

GRAFIK Eye QS Zone	Zone Configuration	Controls DMX address(es)	Fixture affected
1	RGB/CMY DMX	3,4, and 5	RGB LED fixture
2	DMX	6	Intensity of stage light

Example use cases:

- Scene activation: When you select a pre-programmed scene on the GRAFIK Eye QS control unit, it can send any or all zones on the GRAFIK Eye QS to pre-programmed levels.
- Zone adjustment: The individual zone raise/lower buttons on the GRAFIK Eye QS can be used to fine-tune the levels of each zone. For example, raising zone 2 (shown in the table above) will increase the intensity of the stage light.

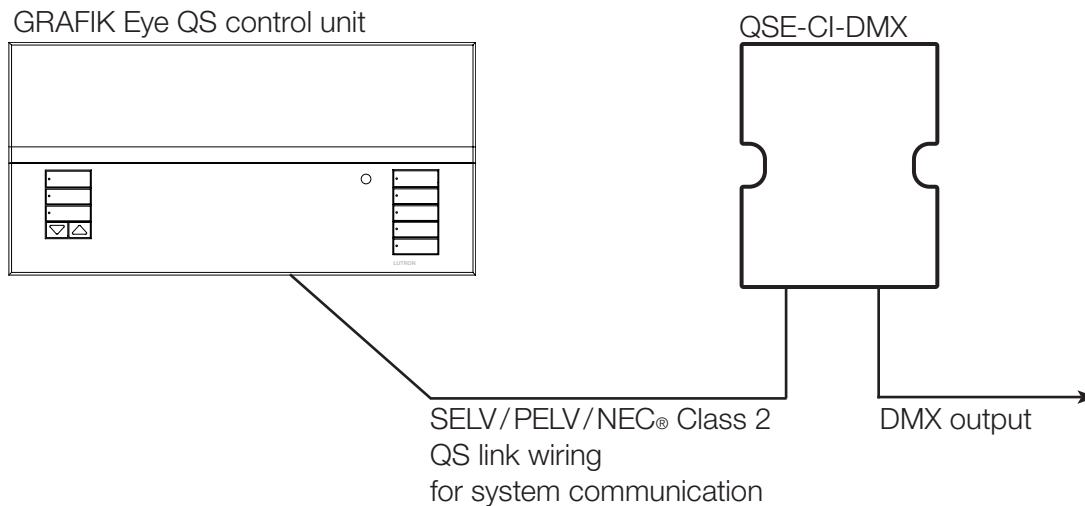

Job Name:	Model Numbers:
Job Number:	

Dimensions

Dimensions are in inches (mm)

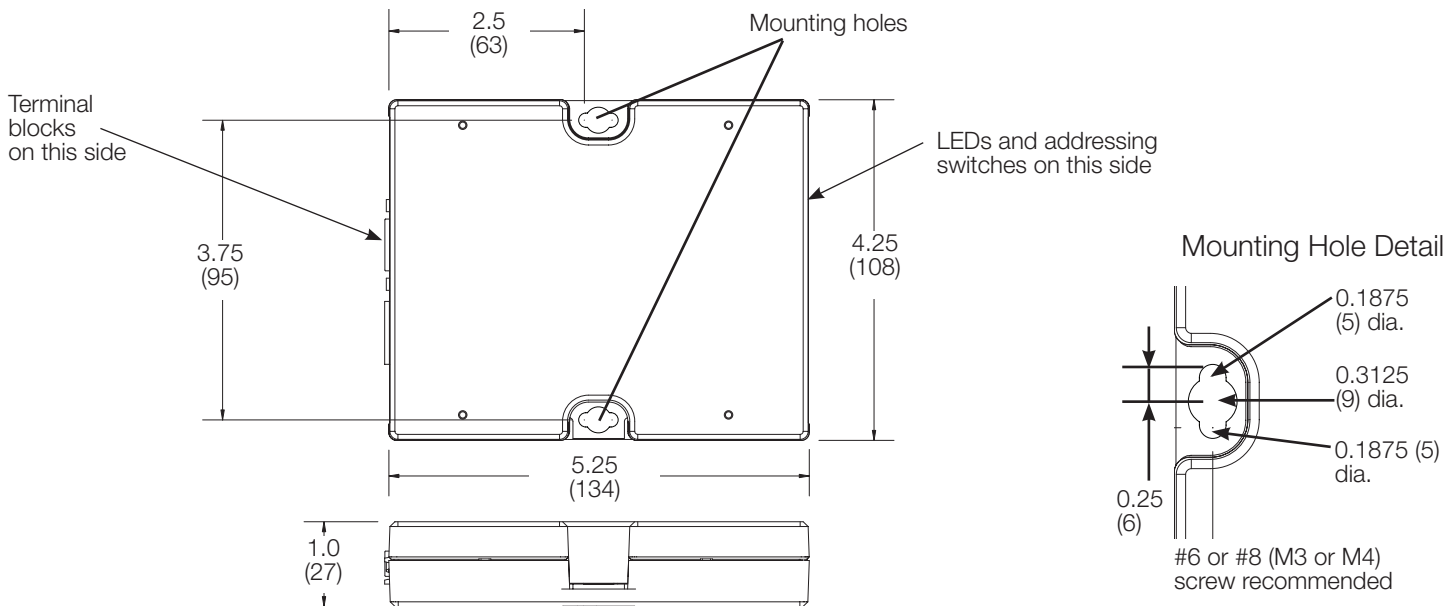

Mounting Options

Mount where terminal blocks, switches, and LEDs are accessible. Strip 3/8 in (10 mm) of insulation from wires. Each data link terminal will accept up to two 18 AWG (1.0 mm²) wires. Connect wiring as shown on the Wiring page. LED 1 is continuously lit (Power) and LED 7 blinks rapidly (Data Link RX) when the SELV/PELV/NEC® Class 2 Data Link is installed correctly. Choose from the following mounting methods:

Mounting Methods

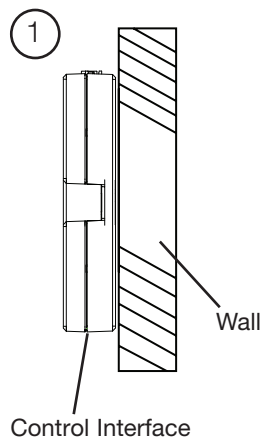

1. Direct Wall Mounting

Mount the control interface directly on a wall, as shown in Mounting Methods at right, using screws (not included). When mounting, provide sufficient space for connecting cables.

2. Rack Mounting

Place the unit in the LUT-19AV-1U AV rack using screws provided with the unit. The LUT-19AV-1U will hold up to four units.

3. Enclosed Wall Mounting

If conduit is desired for wiring, use the LUT-5x10-ENC to mount one unit.

LUTRON SPECIFICATION SUBMITTAL

Job Name:	Model Numbers:
Job Number:	

SELV/PELV/NEC® Class 2 QS Link Requirements and Wiring

- System communication uses SELV/PELV/NEC® Class 2 wiring.
- Wiring can be daisy-chained or T-tapped (see below).
- Wiring must be run separately from line/mains voltage.
- Total length of control link must not exceed 2000 ft (610 m).
- Connect the terminal 1, 3, and 4 connections to all control units, wallstations, and control interfaces. See **Powering the QSE-CI-DMX** for pin 2 connectivity.
- The QSE-CI-DMX consumes 2 Power Draw Units (PDUs) on the QS link. For more information, see **Power Draw Units on the QS Link**, PN 369405, at www.lutron.com/qs

Wire Sizes (check compatibility in your area)

QS Link Wiring Length	Wire Gauge	Lutron Cable Part Number
Less than 500 ft (153 m)	Power (terminals 1 and 2) 1 pair 18 AWG (1.0 mm ²)	GRX-CBL-346S (non-plenum) GRX-PCBL-346S (plenum)
	Data (terminals 3 and 4) 1 twisted, shielded pair 22 AWG (0.5 mm ²)	
500 to 2000 ft (153 to 610 m)	Power (terminals 1 and 2) 1 pair 12 AWG (4.0 mm ²)	GRX-CBL-46L (non-plenum) GRX-PCBL-46L (plenum)
	Data (terminals 3 and 4) 1 twisted, shielded pair 22 AWG (0.5 mm ²)	

Daisy-Chain Wiring Example

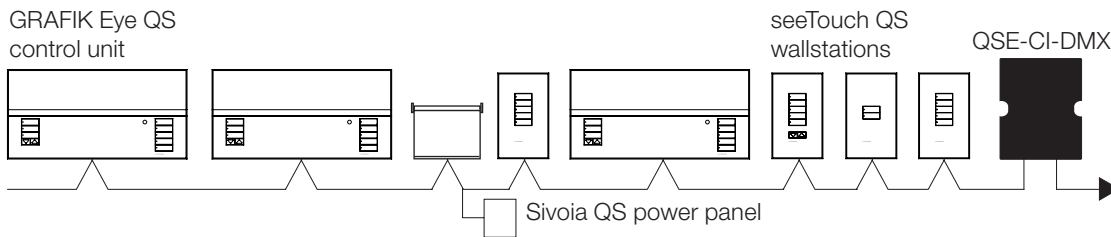

T-Tap Wiring Example

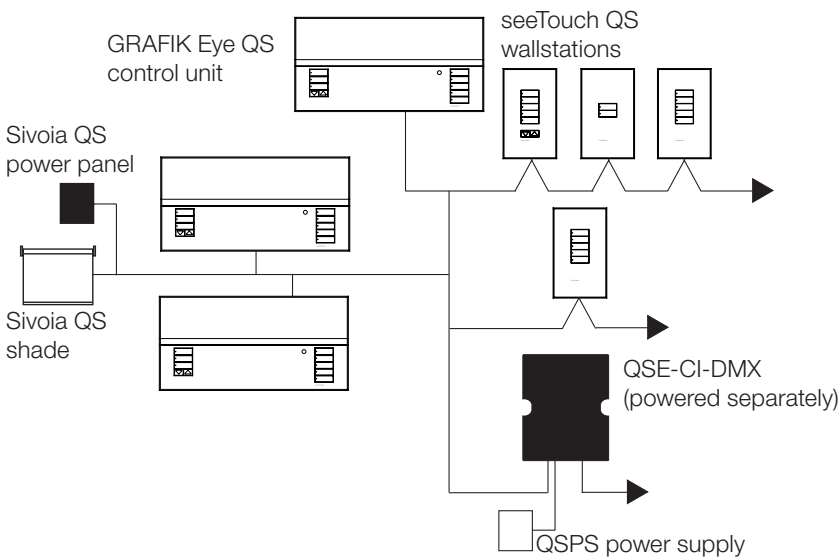

Job Name:	Model Numbers:
Job Number:	

SELV/PELV/NEC® Class 2 Terminal Connections

Wire Sizes (check compatibility in your area)

QS Link Wiring Length	Wire Gauge	Lutron Cable Part Number
Less than 500 ft (153 m)	Power (terminals 1 and 2) 1 pair 18 AWG (1.0 mm ²)	GRX-CBL-346S (non-plenum) GRX-PCBL-346S (plenum)
	Data (terminals 3 and 4) 1 twisted, shielded pair 22 AWG (0.5 mm ²)	
500 to 2000 ft (153 to 610 m)	Power (terminals 1 and 2) 1 pair 12 AWG (4.0 mm ²)	GRX-CBL-46L (non-plenum) GRX-PCBL-46L (plenum)
	Data (terminals 3 and 4) 1 twisted, shielded pair 22 AWG (0.5 mm ²)	

Connect Drain/Shield as shown. Do not connect to Ground (Earth) or Wallstation/Control Interfaces. Connect the bare drain wires and cut off the outside shield.

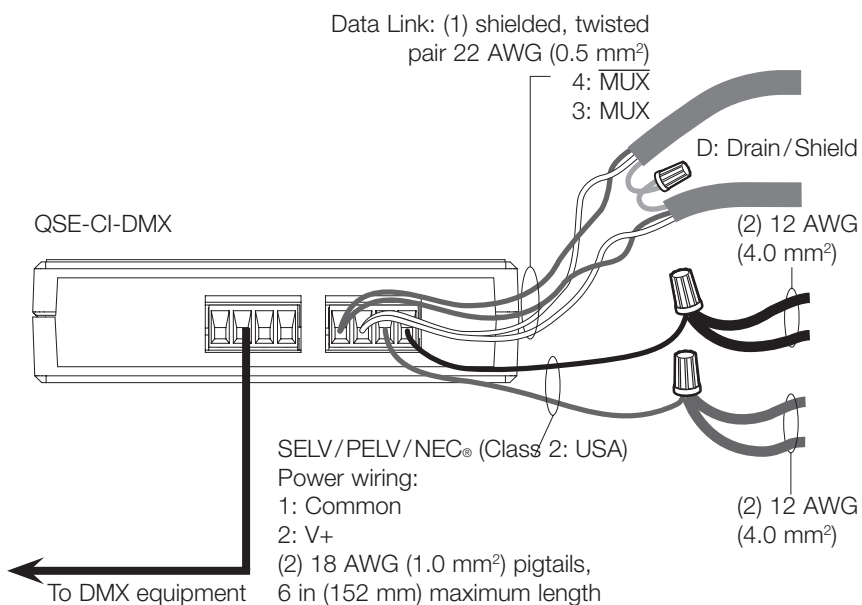

Note: Do not connect Drain/Shield to Ground (Earth) or Wallstation/Control Interfaces. Connect the bare drain wires and cut off the outside shield.

Note: 12 AWG (2.5 mm²) conductors for Common (terminal 1) and V+ Power (terminal 2) will not fit in terminals; use 18 AWG (1.0 mm²) pigtails (< 6 in [152 mm]).

Job Name:	Model Numbers:
Job Number:	

Powering the QSE-CI-DMX

- The QSE-CI-DMX requires 2 PDUs (Power Draw Units) on the QS link. The GRAFIK Eye QS outputs 3 PDUs on the QS link, so it is capable of powering a single QSE-CI-DMX with 1 PDU to spare.
- The QSE-CI-DMX can also be powered from a QS Link power supply (QSPS-P1-1-35V, QSPS-P2-1-35V, or QSPS-P3-1-35V); a QS shade panel power supply (QSPS-10PNL for 230 V~, or QSPS-10PNL for 120 V~); or a Quantum light management hub.
- For more information on PDUs (Power Draw Units), see the Lutron PDU Spec Submittal (P/N 369405) at www.lutron.com

Wiring Examples

QSE-CI-DMX Powered by a GRAFIK Eye QS Control Unit

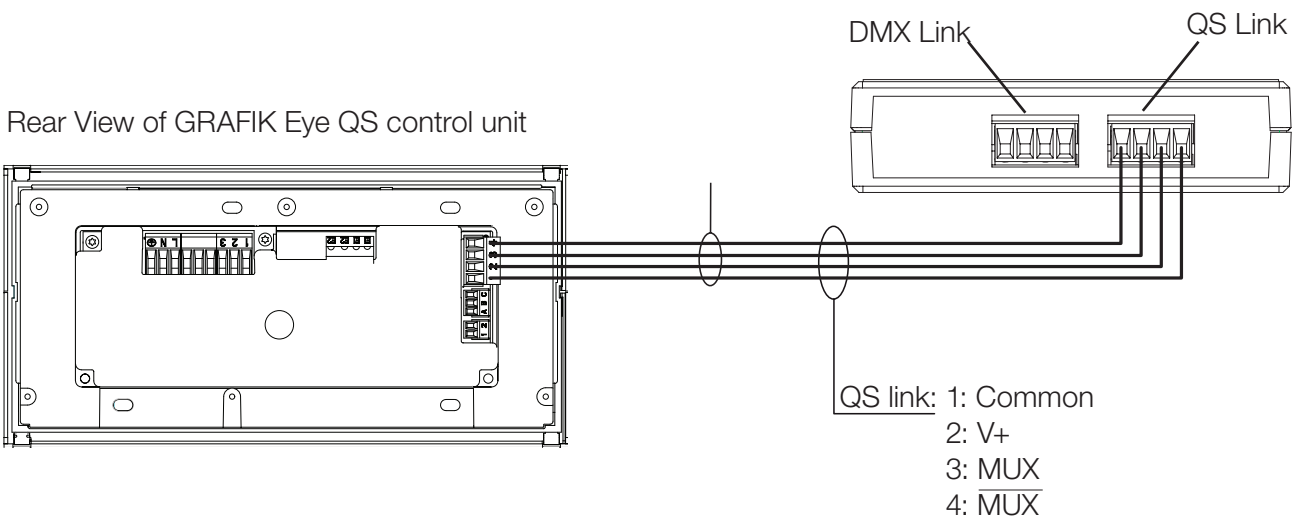

QSE-CI-DMX Powered by a QSPS Power Supply

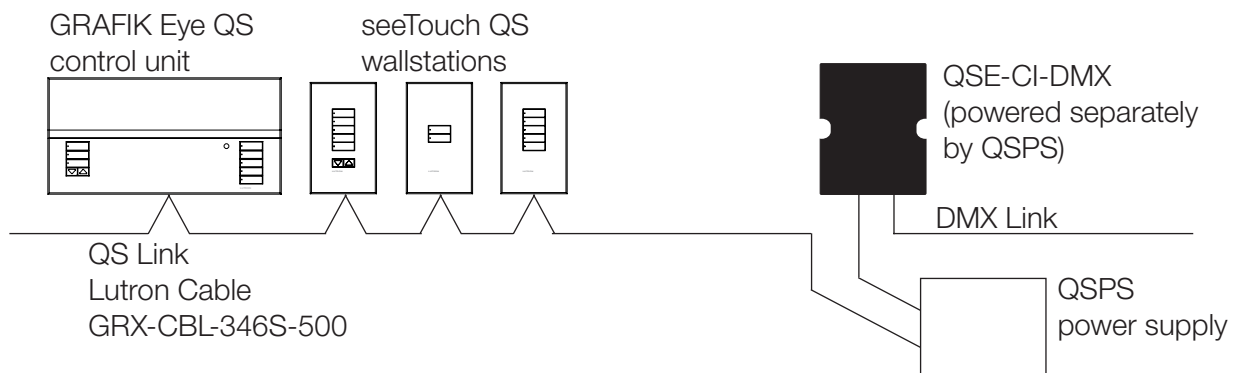

Job Name:	Model Numbers:
Job Number:	

DMX512 Link Wiring

Connect the DMX link terminals on the QSE-CI-DMX interface to input terminals on DMX512-controlled equipment.

- Each terminal on the QSE-CI-DMX accepts two 18 AWG (1.0 mm²) wires.
- Link must be 1000 ft (305 m) or less.
- Link must begin and end with link terminators (available from Lutron; part number LT-1a).

Pin on QSE-CI-DMX Terminal	Connection to DMX Equipment
1: DMX512 system COMMON	DMX512 system COMMON Note: Do NOT connect to COMMON on GRAFIK Eye QS control unit or other Lutron equipment
NC	Not connected
3: DMX512 system DATA +	DMX512 system DATA +
4: DMX512 system DATA -	DMX512 system DATA -

Lutron, Athena, GRAFIK Eye, HomeWorks, seeTouch, Sivoia, Q-Design, Quantum, and any related trade dress and logos are trademarks or registered trademarks of Lutron Electronics Co., Inc. in the US and/or other countries.

All other product names, logos, and brands are property of their respective owners.

 SPECIFICATION SUBMITTAL

Page

Job Name:	Model Numbers:
Job Number:	